



D1-60A-V module

**Indicator for six voltage inputs
with 12 alarm outputs
and hysteresis control**

User's guide

***D1-60A-V module
Indicator for six voltage inputs
with 12 alarm outputs
and hysteresis control***

User's guide
Version: 06 April 2003

*Information in this document is subject to change without notice and does not represent a commitment on the part of SIELCO.
All trademarks or registered trademarks are property of their respective holders and are hereby acknowledged.*

Sielco S.r.l.
via Marcantonio Colonna, 12 – 20149 Milano – Italy
<http://www.sielco.com>

Contents

- 1 Installation..... 1**
 - 1.1 Packaging check 1
 - 1.2 Dimensions 2
 - 1.3 Fixing method 4
 - 1.4 Physical module description..... 5
 - 1.5 Supply..... 9
 - 1.6 Inputs 9
 - 1.6.1 Digital inputs 9
 - 1.6.2 Analog inputs 9
 - 1.7 Digital control and alarms outputs 10
 - 1.8 Serial communication..... 11
 - 1.8.1 Serial link 11
 - 1.8.2 Communication protocol..... 12
 - 1.8.3 Device identification 12
 - 1.8.4 Serial cable 13
 - 1.9 F1-10 operator panel 13
 - 1.10 Earth wiring and shielding 14
 - 1.10.1 Earth wiring..... 14
 - 1.10.2 Inputs shielding 14
- 2 Operation..... 15**
 - 2.1 Introduction 15

1 Installation

2.2 Input configuration.....	15
2.3 Regulating outputs configuration.....	16
2.4 Supervision	16
2.5 Self-test led	17

3 User Interface.....18

3.1 Introduction.....	18
3.2 Operator panel F1-10	18
3.2.1 Keyboard.....	19
3.2.2 Frontal leds.....	20
3.2.3 Default page	20
3.2.4 Main menù	20
3.2.5 Alarm reset.....	21
3.2.6 Configuration	21
3.2.7 Diagnostics.....	24
3.3 Supervision PC.....	25

A Gates list.....26

A.1 Numeric gates (Holding Registers).....	26
A.2 Digital gates (Coils)	30

1 Installation

1.1 Packaging check

Before starting installation, it is necessary to check that the packaging contents is in compliance with your order. In the packaging there must be:

- # 1 D1-60AV series module
- # 1 instruction manual
- # 1 F1-10 operator panel (optional)
- # 1 F1-10 9 pin cable (optional)

Check that the model code is in compliance with the ordered code and verify that the manual edition correspond to the purchase year.

D1-60AV device provide the following features:

- 24 Vcc supply
- 6 voltage inputs:
 - sensor type: 0-5V
 - Input impedance: 20 k Ω
 - resolution: 16 bit
 - accuracy: $\pm 0,05$ % full scale
- 2 digital inputs
 - common negative optoisolated
 - state 0: 0..5 Vcc
 - state 1: 7..36 Vcc
- 12 digital outputs:
 - PNP transistor optoisolated (24V)

1 Installation

D1 series modules are covered by 1 year of warranty except for damages caused by tampering or wrong wiring.

The label on the modules backside certifies the purchase date.

1.2 Dimensions

The D1-60AV modules dimensions are shown in figure 1.1.

1.2 Dimensions

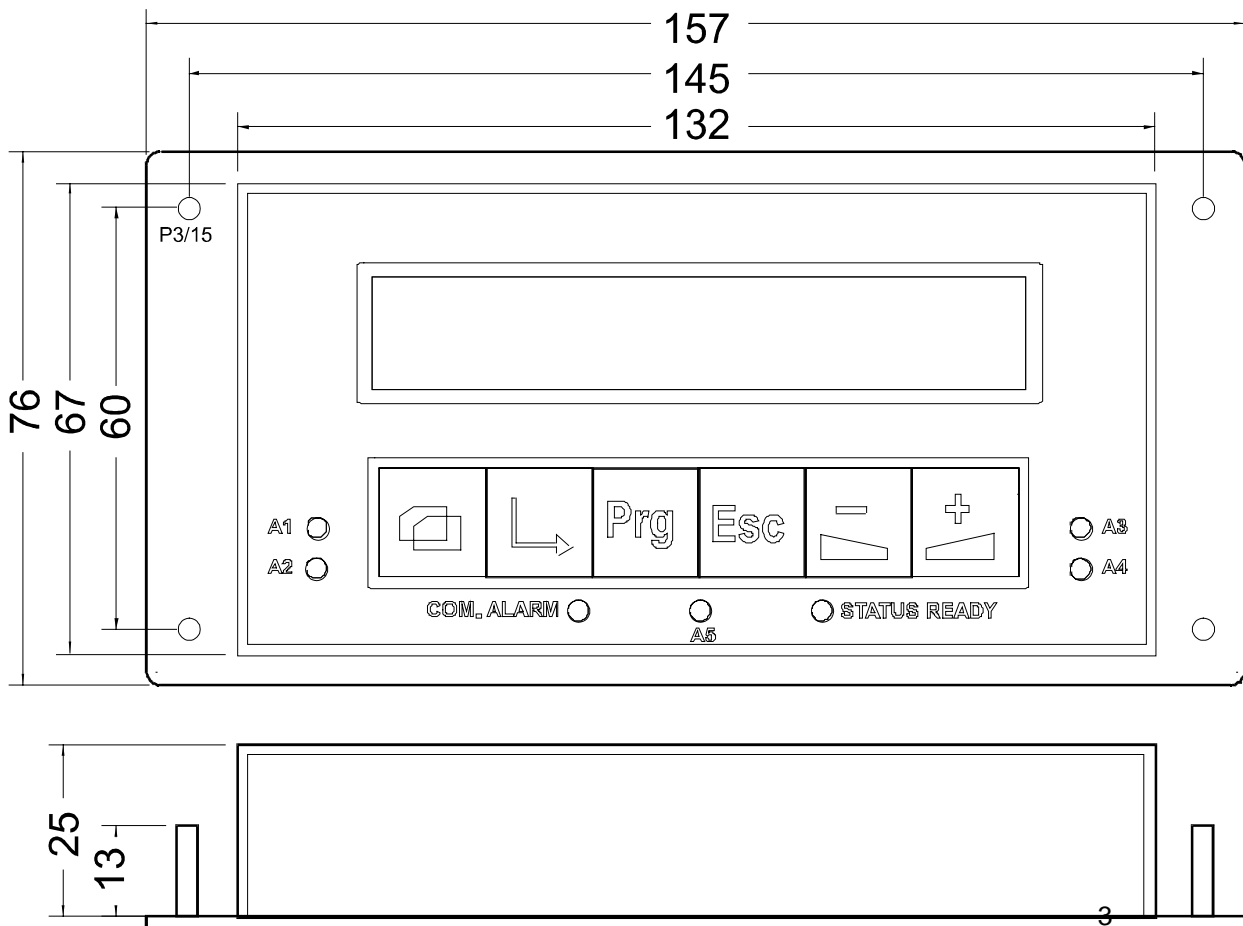
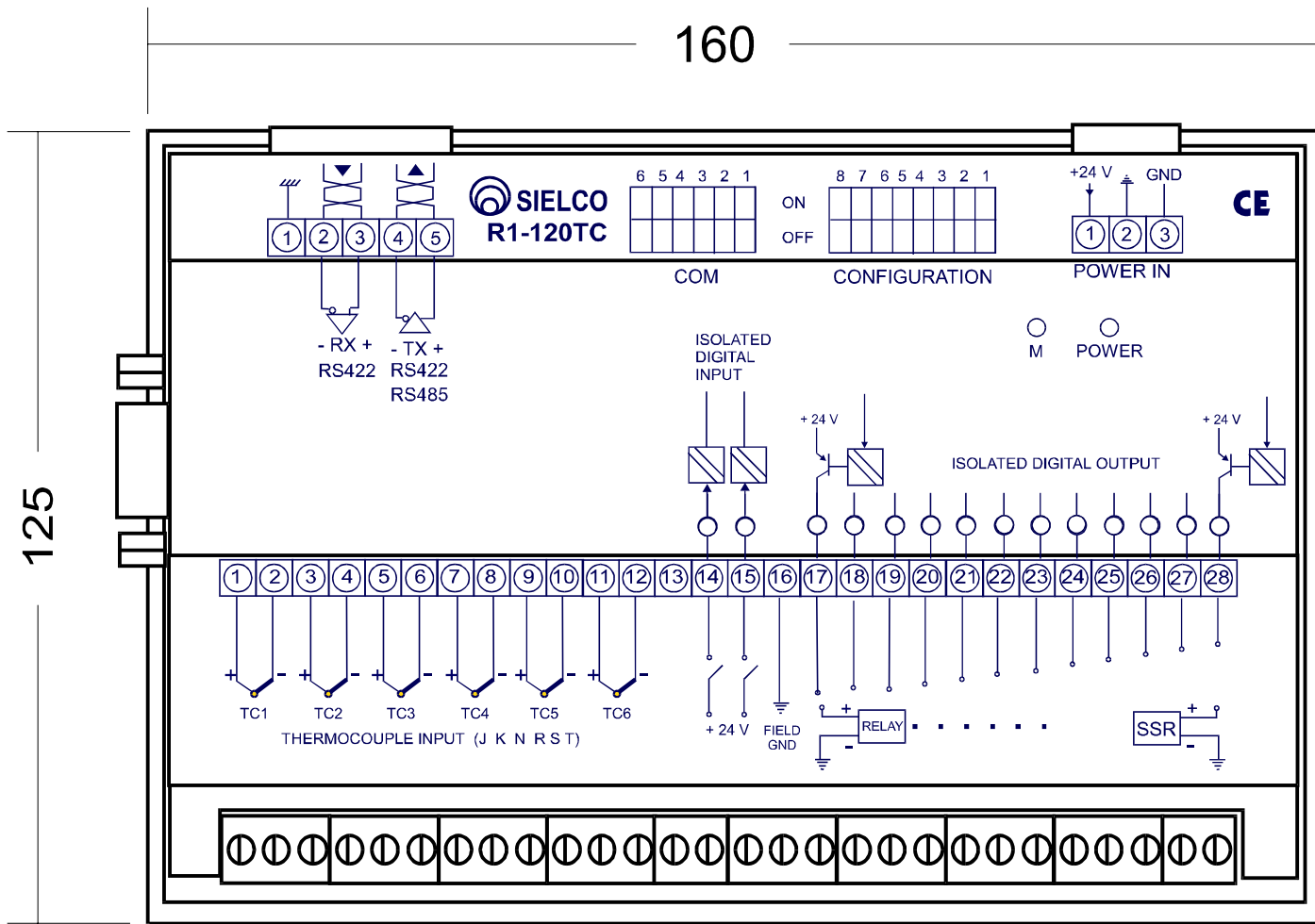

Figure 1.1 - D1-60 module and F1-10 panel dimensions

1.3 Fixing method

All D1 series products are provided by a plastic support for fixing on normalized DIN EN rail and by a shielding serigraphed cover.

On the cover there are schematic mounting indications; in grey areas are shown the interface circuits that are inside the module, in yellow areas common use sensors and actuators to be connected externally.

The cover serigraph provides only a general wiring diagram and cannot show every possible connection cases; for this reason it is necessary to read carefully this manual before starting module installation.

Do not use excessive pressure on the cover, mounting or dismounting the module on the rail. Remember to do these operations with supply voltage switched off or not connected.

F1-10 console is provided in option for panel mounting. Panel hole dimensions are shown in figure 1.2.

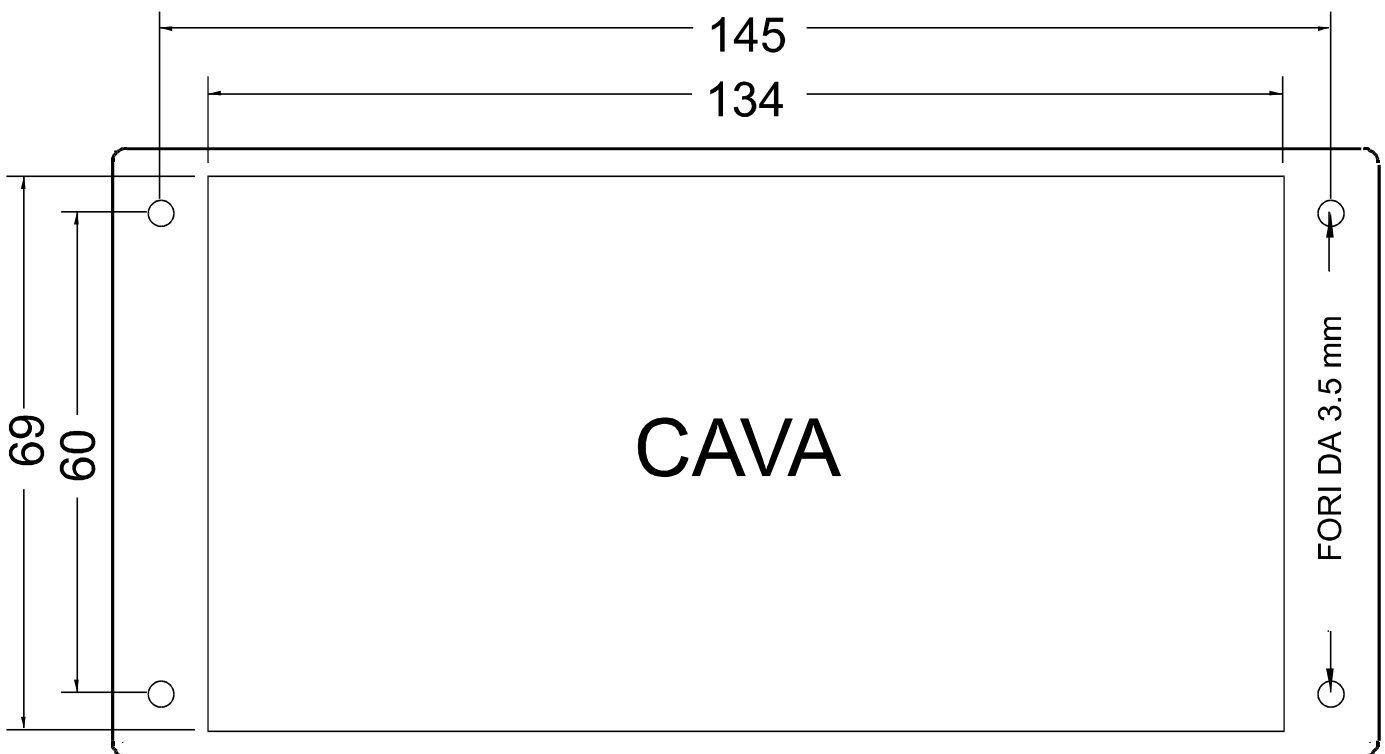

Figure 1.2 - F1-10 panel hole dimension

1.4 Physical module description

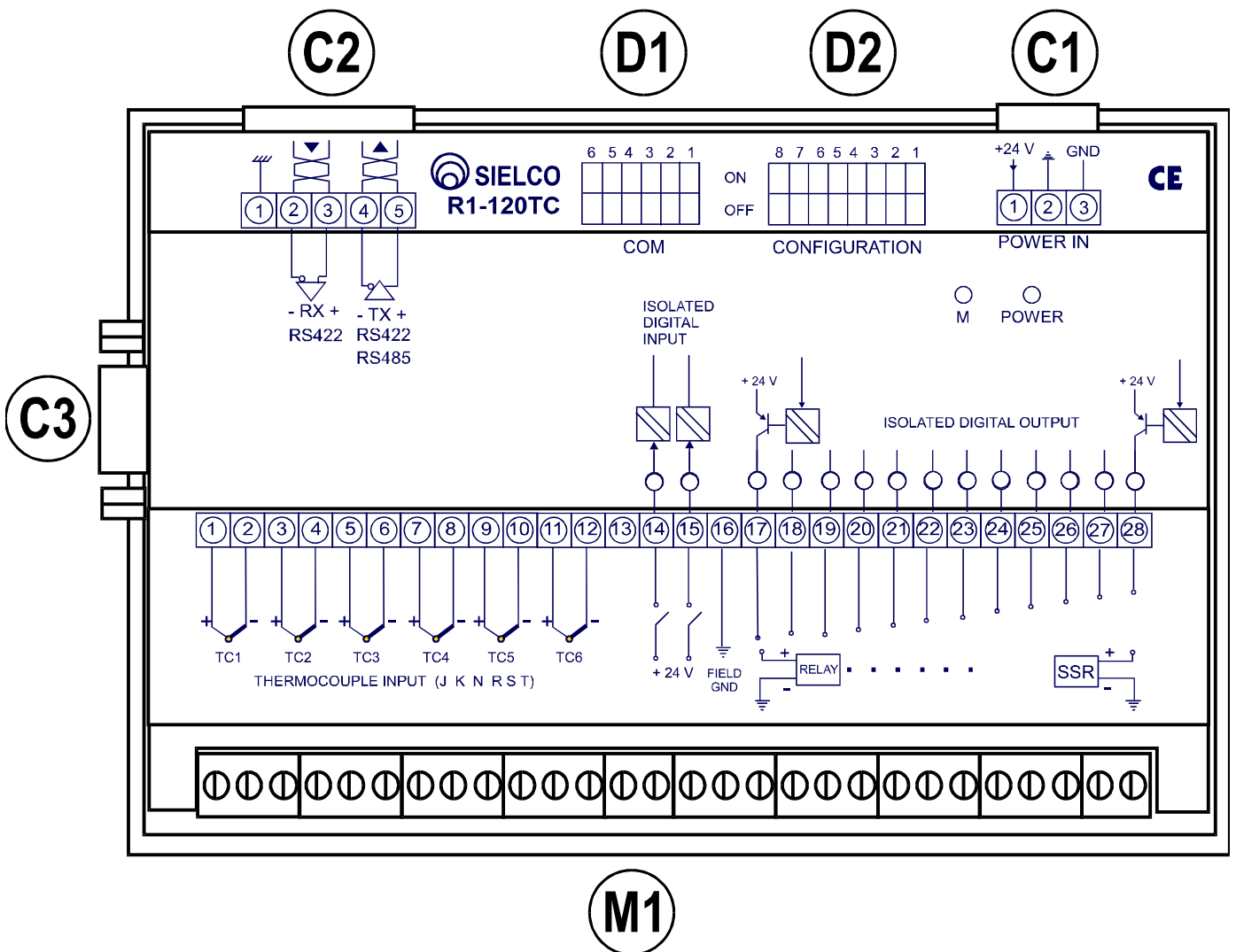
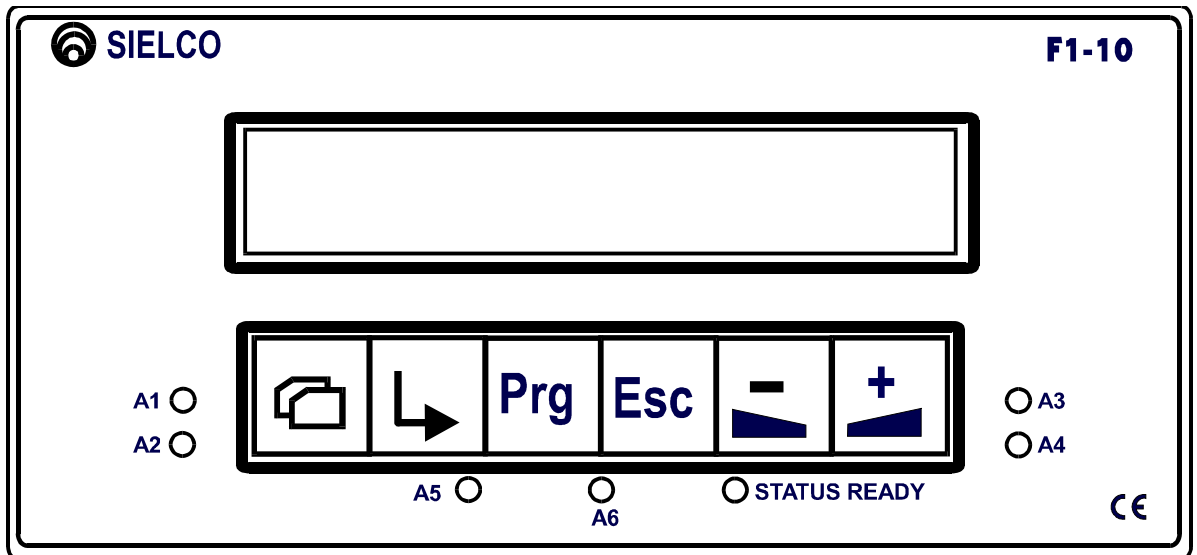

Figure 1.3 - D1-60 and F1-10 scheme

	Description
[C1]	+24 Vdc supply connector
[C2]	RS422/485 serial channel connector
[C3]	F1-10 panel connector
[M1]	Input and output screws
[D1]	RS422 or RS485 line selection dipswitch
[D2]	Protocol and device address selection dipswitch
Led +24	Supply led
Led M	Selftest led (normally blinking)
Led TX	Transmitted data led
Led RX	Received data led
Led 1..26	Digital inputs and output status
Led 27	Safe-state led

[M1] - Input and output screws

	VOLTAGE INPUT
1	Channel 1 positive
2	Channel 1 negative
3	Channel 2 positive
4	Channel 2 negative
5	Channel 3 positive
6	Channel 3 negative
7	Channel 4 positive
8	Channel 4 negative
9	Channel 5 positive
10	Channel 5 negative
11	Channel 6 positive
12	Channel 6 negative

	DIGITAL INPUT
14	Digital input 1
15	Digital input 2

	FIELD GROUND
16	Field ground

	DIGITAL OUTPUT
17	Digital output 1
18	Digital output 2
19	Digital output 3
20	Digital output 4
21	Digital output 5
22	Digital output 6
23	Digital output 7
24	Digital output 8
25	Digital output 9
26	Digital output 10
27	Digital output 11
28	Digital output 12

Screw #13 in not used.

[C1] - +24 Vdc supply connector

	POWER
1	+24 Vdc
2	FIELD GND
3	MECH. GND

[C2] - RS422/485 serial channel connector

	RS422		RS485
1	SERIAL GND	1	SERIAL GND
2	RX-	2	N.C.
3	RX+	3	N.C.
4	TX-	4	TX-/RX-
5	TX+	5	TX+/RX+

1.5 Supply

The D1-6TC module needs a 24 Vdc ($9V < Vdc < 36V$) supply by [C2] connector and absorb a maximum current $I_{cc}=200$ mA at 24 Vdc.

The negative power supply must be connected to pin #2 [C2] connector.

After power is turned on, check that +24 led is on.

1.6 Inputs

1.6.1 Digital inputs

D1-60AV modules are equipped with 2 digital inputs with negative common negativo (M1 screws).

Input status is OFF for voltage between 0 and 5 Vdc, ON for voltage between 7 and 36 Vdc.

1.6.2 Analog inputs

D1-60AV module provides 6 input for 0-5V voltage signals (M1 screws). To maintain input optical insulation, sensor supply must be separate. Connect “positive” and “negative” sensors wires respectively to “positive” and “negative” module screws (respectively #1 and #2 for first input) see figure 1.3.

1.7 Digital control and alarms outputs

D1-60AV module is provided with 12 optically isolated, “open collector”, logic outputs with 24 Vdc PNP transistor and suppression diode (output I_{max} for channel is 100mA, see figure 1.4).

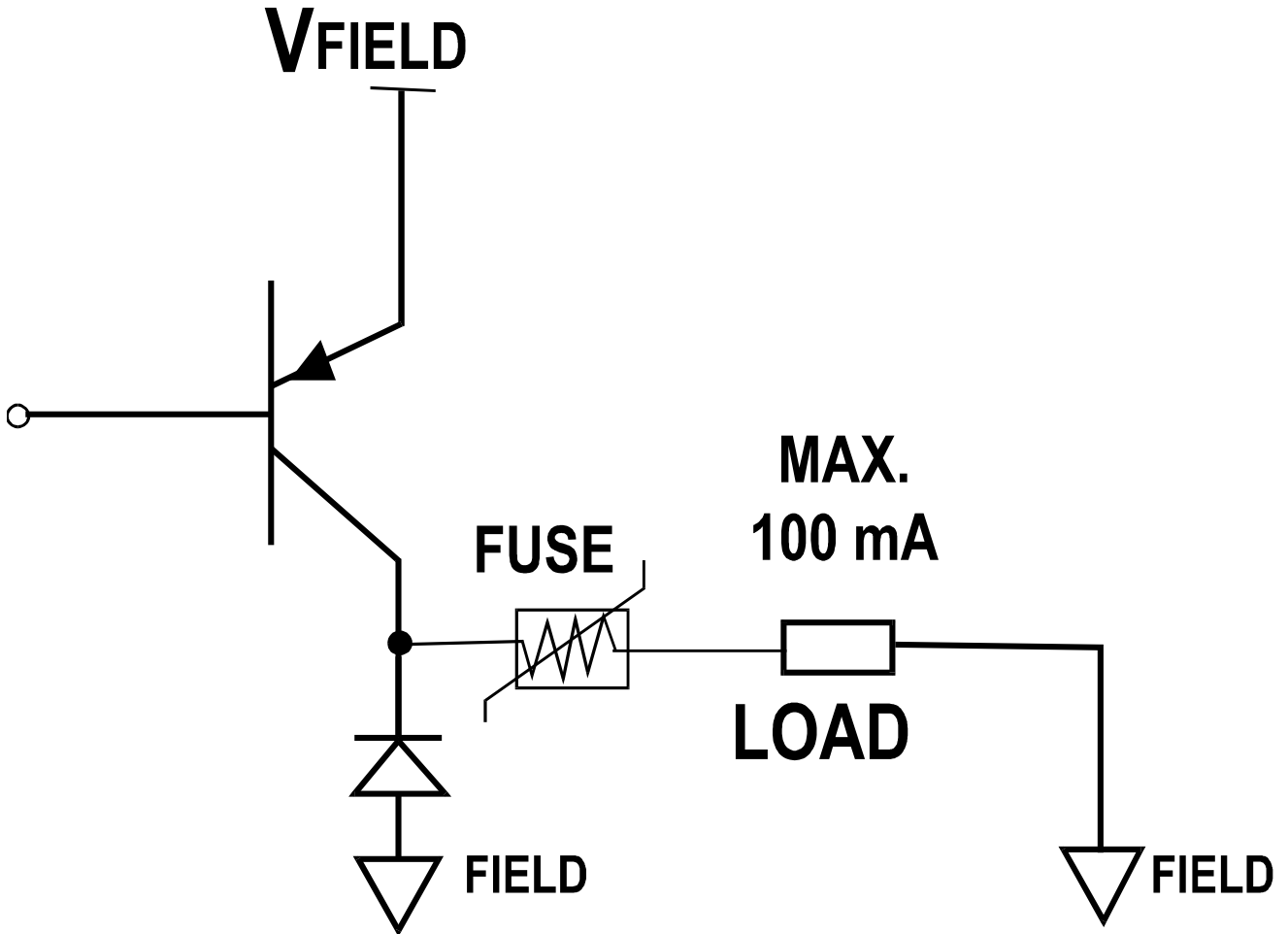

Figure1.4 - Digital output

These outputs can be used to command relays or solid state relays (SSR). Verify that the internal solid state relay resistance limits the current to the above value. Verify that the SSR model is in compliance with what specified above.

In case of relays that drive inductive loads, we suggest to put in parallel a protection filter according to table 1.1; filters must use polyester capacitors.

LOAD (mA)	C (μF)	Vmax (V)	R (Ω)	P (W)
< 40	0,047	400	100	0,5
< 150	0,1	400	22	2

< 500	0,33	400	47	2
> 500	1	400	---	---

Table 1.1 - Filters for capacitor loads

Connect “positive” wires coming from the actuator to screw from #17 to #28 of [M1] screws and “negative” wires to screw #16 (FIELD GND) of [M1] screws.

1.8 Serial communication

1.8.1 Serial link

To connect to D1 modules, it is necessary to use a RS422/485 serial interface that usually are not standard equipment in personal computers.

SIELCO produces C1-25 model, a RS232-RS422/485 serial interface converter with triple optical isolation that can be connected to PC serial port (COM) and to D1-60AV [C2] connector as shown in table 1.2.

C1-25			D1-60		
#	RS-422		RS-422	#	
1	GND	↔	SERIAL GND	1	C2
2	RX-	↔	TX-	4	C2
3	RX+	↔	TX+	5	C2
4	TX-	↔	RX-	2	C2
5	TX+	↔	RX+	3	C2
6	0 V				
7	+24 V				

C1-25			D1-60		
#	RS-485		RS-485	#	
1	GND	↔	SERIAL GND	1	C2
2	n.c.		n.c.	2	C2
3	n.c.		n.c.	3	C2
4	TX-/RX-	↔	TX-/RX-	4	C2
5	TX+/RX+	↔	TX+/RX+	5	C2
6	0 V				
7	+24 V				

Table 1.2 - C1-25 - D1-60 (RS 422/485) wiring

D1-60AV serial communication must be set in RS422 or RS485 mode using [D1] dipswitch (table 1.3).

RS422							RS485						
	6	5	4	3	2	1		6	5	4	3	2	1
ON		■					ON	■					
OFF	■		■	■	■	■	OFF		■	■	■	■	■

Table 1.3 - Line type (RS422/RS485) configuration using dipswitch [D1]

WARNING! Configurations in which both selectors #5 and #6 are simultaneously ON or OFF, are not permitted.

Selector from #1 to #4 are reserved and they must be kept in OFF position.

1.8.2 Communication protocol

Software communication protocol is realised according to Modbus ASCII or RTU standard: protocol selection is made by #7 selector of dipswitch [D2] (ON=RTU, OFF=ASCII).

The baudrate selection is made by #8 selector of dipswitch [D2] (ON=19200, OFF=9600).

ASCII protocol features

Baud rate 9600 / 19200
 Data bits 7
 Parity bit even
 Stop bit 1

RTU protocol features

Baud rate 9600 / 19200
 Data bits 8
 Parity bit none
 Stop bit 1

1.8.3 Device identification

To D1-60AV module can be assigned an identification address between 1 and 63 through binary notation, using selector from 1 to 6 of dipswitch [D2] (see table 1.4).

		ADDRESS							
		8	7	6	5	4	3	2	1
		<i>BAUD</i>	<i>PROT.</i>	2^5	2^4	2^3	2^2	2^1	2^0
ON	19200	RTU							
OFF	9600	ASCII							

Table1.4 - Address configuration using [D2] dipswitch

NOTE

Address 0 is reserved.

1.8.4 Serial cable

Use shielded cable with one (RS-485) or two (RS-422) twisted pair in compliance with EIA RS-485 or EIA RS-422; using the shield for ground.

Recommended cable: *Belden 9841 (RS-485); 9842 (RS-422)*

Maximum signal loss: *6 dB*

Maximum line capacitance: *100 nf*

Maximum line length: *1200 m*

Line impedance: *tra 100 e 120 ohm*

1.9 F1-10 operator panel

D1-60AV modules can be interfaced with the F1-10 operator panel that is equipped with: (see fig. 1.3):

- Seven signalling leds:

A1 - Led 1 (can display the status of a digital output)

A2 - Led 2 “

A3 - Led 3 “

A4 - Led 4 “

A5 - Led 5 “

A6 - Led 6 “

STATUS READY - On if the device is working

- a LCD alphanumeric display 2 x 24 characters

- Six control keys:



Page



Prog



Inc



Enter



Esc



Dec

The connection between D1-60 and F1-10 panel must be done using the cable included in the package by [C3] connector. Don't use different cables.

1.10 Earth wiring and shielding

1.10.1 Earth wiring

It is suggested to make the following earth:

- device mechanical ground (connector [C1] pin #3) goes directly to earth;
- the power supply negative signal (connector [C1] pin #2) must be connected to a local earth;
- in case of long or disturbed serial lines, connect serial ground (connector [C2] pin #1) to earth by a 100 Ω resistance.

It is important that device grounds are connected to earth independently; it is also important to avoid to share the same wire path with power devices as inverter, drives etc.

1.10.2 Inputs shielding

To improve the sensors reading particularly in environment noise affected by power devices (motor driver, power contact etc.), follow these shielding rules:

- use shielded and twisted cables for sensors connection;
- keep connection cables as short as possible;
- it is a good thing to avoid to share the same wire path with power devices as inverter, drives etc.;
- connect all sensor cable metal shields to the controller negative screw leaving them non connected by the sensor side (parasite currents on the shields can induce disturbances that can affect sensor reading);
- connect all sensor cable metal shields to connector [C1] pin #3.

2 Operation

2.1 Introduction

D1-60AV module can handle up to 12 independent alarm or hysteresis control outputs related to 6 linear inputs.

Two digital inputs are also available to remotely control some functions

- input number one activates input/output logic.
- input number two reset all retained alarms.

2.2 Input configuration

Input configuration allows independent setting for each channel of parameters for sensor reading ,like sensor type, reading options.

- Sensor type (none, 0-5V sensor)
- Reading options
 - Bit 0 = reading filter
- Linearization value at zero scale
- Linearization value at full scale

Analog current signals range are between 0 and 5V. The acquired value is recorded on a range from 0 to 65000 and is converted in a linear scale between zeroscale value and fullscale value. To obtain a voltage unit value, set zeroscale value at 0 and fullscale value at 5000, dividing for

1000 the read value. To obtain a percentual value, set zeroscale value at 0 and fullscalevalue at 1000, dividing the read value for 10

When the sensor type is set to “none”, the temperature will be forced to 0.

The reading filter is necessary only in case of noisy environment; with the filter the instantaneous values are substituted by a recursive average values calculated on least eight samples.

2.3 Regulating outputs configuration

In output configuration you can define, for each of 12 digital, the following parameters:

- Realted input (0, 1 ... 6)
- Minimum threshold (xxxx.x)
- Maximum threshold (xxxx.x)
- Option and alarm mask:
 - bit 0: hysteresis logic
 - bit 1: minimum alarm
 - bit 2: maximum alarm
 - bit 3: retained alarm
 - bit 4: inverted output
 - bit 5: -----
 - bit 6: -----
 - bit 7: -----
- Switch ON filter (xx sec)
- Switch OFF filter (xx sec)
- Frontal panel led linked (0, 1 ... 6)

Alarm mask allow to generate an alarm output; time filters allow to filter short lenght alarms; frontal leds allow to view allarm presence also on F1-10 frontal panel.

2.4 Supervision

For each channel the following read gates are available, in addition to read/write gates used for the configuration:

- Actual value in engeneered units (xxxx.x)
- Digital inputs status

- Digital outputs status

2.5 Self-test led

Self test led displays the operation status of the device; three cases are possible:

- the led is always on or off; this case indicates a fatal error that can be a consequence of a power failure or device breakdown;
- the led turn on and off constantly: this indicates that the initialization procedure is running, this procedure starts after a reset and it takes about 10 seconds. When the initialization procedure is running the serial communication and the regulation process are disabled;
- the led executes three fast pulses followed by a long pause: this indicates a normal running state.

3 User Interface

3.1 Introduction

Programming and supervision of the device can be handled:

- by mean of the local operator panel F1-10, linked to the device through a dedicated bus; dialogue procedure are explained in paragraph §2 of this chapter.
- by mean of a supervisor PC, linked to various devices through a RS485 bus with Modbus protocol; available gates with their addresses are indicated in in paragraph §3 of this chapter.

3.2 Operator panel F1-10

Operator panel F1-10 is made of a LCD display (2 rows of 24 characters each), 6 programming keys and 7 signalling leds.

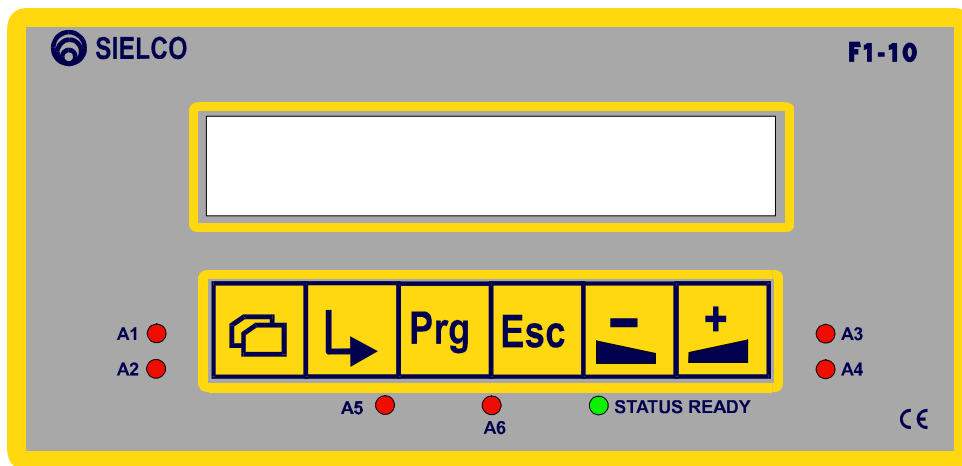

Figure 3.5 - Operator panel F1-10

The operator panel offers different menu driven procedures that allow programming and supervision of the D1-60.





In the default page the six thermocouples temperatures are visualized.

All other pages are made of a title (first row) and a series of items that scroll (second row).

The following paragraphs describe the different pages and the procedures to enter data.

3.2.1 Keyboard

The following table specifies the standard operation of each key:

Key	Description	Operation
	<i>SELECT</i>	Scroll among various menu items.
	<i>ENTER</i>	Goes to a lower level menu (if present).
	<i>PROGRAM</i>	Confirms the data modification.
	<i>ESCAPE</i>	Aborts the data modification or goes to a higher level menu (if present).



DEC

Decrements the selected data value.



INC

Increments the selected data value.

3.2.2 Frontal leds

The “status ready” led on indicates that the device is working properly; all other leds display the status of the related outputs (see paragraph §3.2.7).

3.2.3 Default page



The default page, or main page, is the first page displayed when the controller is turned on. The six sensor values are displayed in engineered unit.

+nnnnn	+nnnnn	+nnnnn
+nnnnn	+nnnnn	+nnnnn

Pressing key enter  you can select the main menu.



3.2.4 Main menù

From the main menu you can go to the supervision menu, the programming menu, the configuration menu and the diagnostic menu.

With the selection key  you can rotate the various menu items and with the enter key  you go to the next menu level.

* MAIN MENU*
- Alarm reset
- Configuration
- Diagnostics
- Language : sssssss [Italiano,English]





The last row allow to select the language.

With  and  data can be modified, with  new data can be confirmed.

3.2.5 Alarm reset

In this page is possible to individually reset retained alarms.

```
01* 02 03 04* 05 06
07 08 09* 10 11 12
```

Selection key  switches to next output; escape key  returns to previous menu. Asterisk presence on the right of output number, shows that this output is retained. Keys  and  allow to turn off the asterisks to reset alarms and so to switch off the related digital outputs. Alarm reset takes effect only if in that moment alarm conditions are not still present.

3.2.6 Configuration

The device configuration has two sections: inputs configuration and outputs configuration.

```
* CONFIGURATION MENU *
- Input Configuration
- Output Configuration
```

In case of inputs configuration, choose one of the six channels.

```
* INPUT CONFIGURATION *
- Input 1
- Input 2
- Input 3
- Input 4
- Input 5
- Input 6
```

* INPUT CONFIGURATION N	[1..6]
Sensor type : ssssss	[none, 0-5V, 0-20mA]
Read filter : SSS	[YES/NO]
Digits : sssss	[x x.x x.xx x.xxx]
Value at zero : +nnnnn	[-30000..+30000]
Value at full : +nnnnn	[-30000..+30000]

In the input configuration pages you can set the parameters required to read analog inputs.

When the sensor type is set to “none”, the read value will be forced to 0.

The number of digits specifies the position of the decimal point in the displayed values in F1-10.

It is necessary to specify the linearization parameters. The value at zero scale must be lower than the value at full scale.

A filter has been implemented on the base of 8 samples readed.

In case of outputs configuration, choose one of the 12 channels.

* OUTPUT CONFIGURATION *
- Output 1
- Output 2
- Output 3
- Output 4
- Output 5
- Output 6
- Output 7
- Uscita 8
- Uscita 9
- Uscita 10
- Uscita 11
- Uscita 12

OUTPUT CONFIGURATION	NM	[1..12]
Actual status	: SSS	[ON/OFF]
Input (+nnnn.n)	: n	[1..6]
Hysteresis logic	: SSS	[YES/NO]
Minimum thresh.	:+nnnnn	[-30000..+30000]
Maximum thresh.	:+nnnnn	[-30000..+30000]
Minimum alarm	: SSS	[YES/NO]
Maximum alarm	: SSS	[YES/NO]
Retention	: SSS	[YES/NO]
ON filter [sec]	: nnn	[0..240]
OFF filter [sec]	: nnn	[0..240]
Inverted output	: SSS	[YES/NO]
Frontal led	: n	[1..6]

Single outputs configuration is independent from inputs one. There is no physical link between inputs and outputs; for example output #1 can be used as alarm for input #4.

“Input” parameter specifies which analog input has to be related with digital output. If the value 0 is chosen (no analog input), the output will assume the following state:

- ON if the parameter “Inverted output” is “NO”
- OFF if the parameter “Inverted output” is “YES”

In that case the other parameter setting does not have any effect.

The “Hysteresis logic” parameter allows to choose which alarm logic to apply. “NO” for simple threshold; “YES” for a hysteresis control.

In case of simple threshold logic

The parameters “Minimum threshold” and “Maximum threshold ” are respectively the minimum and the maximum value that the analog input can assume without alarm switches on.

In case of hysteresis control logic

The parameters “Minimum threshold” and “Maximum threshold ” are respectively the analog input value below which output switches off and above which output switches on.

In both cases, maximum threshold value must be greater than minimum threshold one. In case of the values set do not respect this condition, D1-60AV device keeps user minimum value and forces maximum value as minimum value increased by 0.1

The parameters “Minimum alarm” and “Maximum alarm ” enable the respective alarms simple threshold. These parameters are ignored in case of hysteresis control logic.

The parameter “Retention” show if the digital output, that has switched on in alarm conditions, has to be retained even after the alarm conditions will end. The “retained output” condition is stored in permanent memory, so the device power off does not mean this condition loss. To reset retention condition (alarm reset), it is possible to operate in two ways: switching on digital input # 2 (all retained alarms reset) or using “Alarm reset” menu and reset independently each. Alarm reset takes effect only if in that moment alarm conditions are not still present. When an alarm is retained there are some operations that, as secondary effect, reset the alarm:

- 1) to deactivate completely alarm logic (deactivate digital input #1)
- 2) to set the parameter “Input” to 0 (none)
- 3) to set the parameter “Retention” to “NO”
- 4) to set the parameter “Hysteresis logic” to “YES”

Retention is ignored in case of hysteresis.

The parameters “ON filter” and “OFF filter” are respectively the periods of time for which alarm conditions must remain and cease to activate and deactivate alarm output. Setting these periods as 0 the alarm output switching on and off are immediate. Example: if “ ON filter ” is 5 seconds and the alarm conditions remain only for 3 seconds, digital output does not switch on. This is not an accumulation filter, so if these conditions will return later, they must remain again 5 seconds to switch on the digital output. The “OFF filter” works in the same way.

The parameter “Inverted output” allow to make an output “non active” in case of alarm conditions and an output “ active” ” in case of no alarm conditions.

Example: if logic decides that an output must be active:

- with “ Inverted output “ = “NO”, we will have active output
- with “ Inverted output “= “YES”, we will have non active output

The parameter “Frontal led” allow to associate an output status to one of the six F1-10 frontal leds. In this way. Set this parameter as 0 for no frontal led association. Avoid to associate the same led to more than one output.

3.2.7 Diagnostics

Diagnostic pages are useful during device installation and to verify the correct working.

In the diagnostic menu you can display the pages related to digital inputs/outputs, serial communication and analog inputs.

<pre> * DIAGNOSTICS * - Digital I/O - Analog inputs </pre>
--

In the digital input diagnostic you can see their actual status.

In the digital output diagnostic you can see and modify their actual status

<pre> * I/O DIAGNOSTICS * IN:XX OUT:XXXXXXXXXXXX [0,1] </pre>

In the communication diagnostic page you can see the values set by the microswitch on the board: device address, baud rate and Modbus protocol type.

<pre> * COMM. DIAGNOSTICS * Device address : nn [1..63] from switch Baud Rate : sssss [9600/19200] from switch Protocol : sssss [ASCII/RTU] from switch </pre>

3.3 Supervision PC

The WINLOG-A software provides an operator interface in a Windows environment for real-time supervision, historical trend analysis and alarm management: all of the data are recorded in history databases in a format which is accessible from the main software packages (Excel, Access, ..). An integrated development environment provides a toolkit for building templates (Template Builder), defining tags (Gate builder), writing programs (Code Builder) and setting up a complete multilanguage application in a very short time (Application Builder).

To use WINLOG-A software, refer to the Winlog Operation Manual; the communication protocol is the Modbus Rtu; all available gates with relative addresses are listed in Appendix A.

A Gates list

A.1 Numeric gates (Holding Registers)

ADDRESS	DESCRIPTION	UNIT	BYTE	MIN	MAX	FORMAT	READ ONLY
000	Device - Identification "D1"		2	0	0	SS	•
001	Device - Identification "60"	#	2	0	0	nnn	•
002	Device - firmware version	#	2	0	65535	nnn.nn	•
005	Reset counter	#	1	0	255	nnn	
006	Channel 1 – Sensor type	#	1	0	7	n	
007	Channel 2 – Sensor type	#	1	0	7	n	
008	Channel 3 – Sensor type	#	1	0	7	n	
009	Channel 4 – Sensor type	#	1	0	7	n	
010	Channel 5 – Sensor type	#	1	0	7	n	
011	Channel 6 – Sensor type	#	1	0	7	n	
012	Channel 1 - Input options	bit	1	0	3	xxxxxxbb	
013	Channel 2 - Input options	bit	1	0	3	xxxxxxbb	
014	Channel 3 - Input options	bit	1	0	3	xxxxxxbb	
015	Channel 4 - Input options	bit	1	0	3	xxxxxxbb	
016	Channel 5 - Input options	bit	1	0	3	xxxxxxbb	
017	Channel 6 - Input options	bit	1	0	3	xxxxxxbb	
024	Ramp offset binary	#	2	0	65535	nnnnn	•

A.1 Numeric gates (Holding Registers)

025	Voltage sample binary	#	2	0	65535	nnnnn	•
028	Channel 1 - Temperature	#	2	-30000	+30000	±nnnnn	•
029	Channel 2 - Temperature	#	2	-30000	+30000	±nnnnn	•
030	Channel 3 - Temperature	#	2	-30000	+30000	±nnnnn	•
031	Channel 4 - Temperature	#	2	-30000	+30000	±nnnnn	•
032	Channel 5 - Temperature	#	2	-30000	+30000	±nnnnn	•
033	Channel 6 - Temperature	#	2	-30000	+30000	±nnnnn	•
034	Channel 1 – Linearization value at 0 scale	#	2	-30000	+30000	±nnnnn	
035	Channel 2 – Linearization value at 0 scale	#	2	-30000	+30000	±nnnnn	
036	Channel 3 – Linearization value at 0 scale	#	2	-30000	+30000	±nnnnn	
037	Channel 4 – Linearization value at 0 scale	#	2	-30000	+30000	±nnnnn	
038	Channel 5 – Linearization value at 0 scale	#	2	-30000	+20000	±nnnnn	
039	Channel 6 – Linearization value at 0 scale	#	2	-30000	+20000	±nnnnn	
040	Channel 1 – Linearization value at full scale	#	2	-30000	+30000	±nnnnn	
041	Channel 2 – Linearization value at full scale	#	2	-30000	+30000	±nnnnn	
042	Channel 3 – Linearization value at full scale	#	2	-30000	+30000	±nnnnn	
043	Channel 4 – Linearization value at full scale	#	2	-30000	+30000	±nnnnn	
044	Channel 5 – Linearization value at full scale	#	2	-30000	+30000	±nnnnn	
045	Channel 6 – Linearization value at full scale	#	2	-30000	+30000	±nnnnn	
046	Menu language	#	1	0	1	n	
047	Digital inputs status	#	1	0	3	n	•
048	Digital outputs status	#	2	0	4095	nnnn	
049	Output 1 – Input channel	#	1	0	6	n	
050	Output 2 – Input channel	#	1	0	6	n	
051	Output 3 – Input channel	#	1	0	6	n	
052	Output 4 – Input channel	#	1	0	6	n	
053	Output 5 – Input channel	#	1	0	6	n	
054	Output 6 – Input channel	#	1	0	6	n	
055	Output 7 – Input channel	#	1	0	6	n	
056	Output 8 – Input channel	#	1	0	6	n	
057	Output 9 – Input channel	#	1	0	6	n	
058	Output 10 – Input channel	#	1	0	6	n	
059	Output 11 – Input channel	#	1	0	6	n	
060	Output 12 – Input channel	#	1	0	6	n	
061	Output 1 – Minimum level	#	2	-30000	+30000	±nnnn.n	
062	Output 2 – Minimum level	#	2	-30000	+30000	±nnnn.n	
063	Output 3 – Minimum level	#	2	-30000	+30000	±nnnn.n	
064	Output 4 – Minimum level	#	2	-30000	+30000	±nnnn.n	
065	Output 5 – Minimum level	#	2	-30000	+30000	±nnnn.n	
066	Output 6 – Minimum level	#	2	-30000	+30000	±nnnn.n	
067	Output 7 – Minimum level	#	2	-30000	+30000	±nnnn.n	
068	Output 8 – Minimum level	#	2	-30000	+30000	±nnnn.n	
069	Output 9 – Minimum level	#	2	-30000	+30000	±nnnn.n	
070	Output 10 – Minimum level	#	2	-30000	+30000	±nnnn.n	
071	Output 11 – Minimum level	#	2	-30000	+30000	±nnnn.n	
072	Output 12 – Minimum level	#	2	-30000	+30000	±nnnn.n	

A Gates list

073	Output 1 – Maximum level	#	2	-30000	+30000	±nnnn.n	
074	Output 2 – Maximum level	#	2	-30000	+30000	±nnnn.n	
075	Output 3 – Maximum level	#	2	-30000	+30000	±nnnn.n	
076	Output 4 – Maximum level	#	2	-30000	+30000	±nnnn.n	
077	Output 5 – Minimum level	#	2	-30000	+30000	±nnnn.n	
078	Output 6 – Maximum level	#	2	-30000	+30000	±nnnn.n	
079	Output 7 – Maximum level	#	2	-30000	+30000	±nnnn.n	
080	Output 8 – Maximum level	#	2	-30000	+30000	±nnnn.n	
081	Output 9 – Maximum level	#	2	-30000	+30000	±nnnn.n	
082	Output 10 – Maximum level	#	2	-30000	+30000	±nnnn.n	
083	Output 11 – Maximum level	#	2	-30000	+30000	±nnnn.n	
084	Output 12 – Maximum level	#	2	-30000	+30000	±nnnn.n	
085	Output 1 – Alarm mask	bit	1	0	31	xxxbbbb	
086	Output 2 – Alarm mask	bit	1	0	31	xxxbbbb	
087	Output 3 – Alarm mask	bit	1	0	31	xxxbbbb	
088	Output 4 – Alarm mask	bit	1	0	31	xxxbbbb	
089	Output 5 – Alarm mask	bit	1	0	31	xxxbbbb	
090	Output 6 – Alarm mask	bit	1	0	31	xxxbbbb	
091	Output 7 – Alarm mask	bit	1	0	31	xxxbbbb	
092	Output 8 – Alarm mask	bit	1	0	31	xxxbbbb	
093	Output 9 – Alarm mask	bit	1	0	31	xxxbbbb	
094	Output 10 – Alarm mask	bit	1	0	31	xxxbbbb	
095	Output 11 – Alarm mask	bit	1	0	31	xxxbbbb	
096	Output 12 – Alarm mask	bit	1	0	31	xxxbbbb	
097	Output 1 – Alarm filter ON	sec	2	0	240	nnn	
098	Output 2 – Alarm filter ON	sec	2	0	240	nnn	
099	Output 3 – Alarm filter ON	sec	2	0	240	nnn	
100	Output 4 – Alarm filter ON	sec	2	0	240	nnn	
101	Output 5 – Alarm filter ON	sec	2	0	240	nnn	
102	Output 6 – Alarm filter ON	sec	2	0	240	nnn	
103	Output 7 – Alarm filter ON	sec	2	0	240	nnn	
104	Output 8 – Alarm filter ON	sec	2	0	240	nnn	
105	Output 9 – Alarm filter ON	sec	2	0	240	nnn	
106	Output 10 – Alarm filter ON	sec	2	0	240	nnn	
107	Output 11 – Alarm filter ON	sec	2	0	240	nnn	
108	Output 12 – Alarm filter ON	sec	2	0	240	nnn	
109	Output 1 – Alarm filter OFF	sec	2	0	240	nnn	
110	Output 2 – Alarm filter OFF	sec	2	0	240	nnn	
111	Output 3 – Alarm filter OFF	sec	2	0	240	nnn	
112	Output 4 – Alarm filter OFF	sec	2	0	240	nnn	
113	Output 5 – Alarm filter OFF	sec	2	0	240	nnn	
114	Output 6 – Alarm filter OFF	sec	2	0	240	nnn	
115	Output 7 – Alarm filter OFF	sec	2	0	240	nnn	
116	Output 8 – Alarm filter OFF	sec	2	0	240	nnn	
117	Output 9 – Alarm filter OFF	sec	2	0	240	nnn	
118	Output 10 – Alarm filter OFF	sec	2	0	240	nnn	
119	Output 11 – Alarm filter OFF	sec	2	0	240	nnn	
120	Output 12 – Alarm filter OFF	sec	2	0	240	nnn	
121	Output 1 – Front panel led	#	1	0	6	n	

A.1 Numeric gates (Holding Registers)

122	Output 2 – Front panel led	#	1	0	6	n	
123	Output 3 – Front panel led	#	1	0	6	n	
124	Output 4 – Front panel led	#	1	0	6	n	
125	Output 5 – Front panel led	#	1	0	6	n	
126	Output 6 – Front panel led	#	1	0	6	n	
127	Output 7 – Front panel led	#	1	0	6	n	
128	Output 8 – Front panel led	#	1	0	6	n	
129	Output 9 – Front panel led	#	1	0	6	n	
130	Output 10 – Front panel led	#	1	0	6	n	
131	Output 11 – Front panel led	#	1	0	6	n	
132	Output 12 – Front panel led	#	1	0	6	n	

A.2 Digital gates (Coils)

ADDRESS	DESCRIPTION	READ ONLY
000	Digital Input 1	•
001	Digital Input 2	•
002	Digital Output 1	
003	Digital Output 2	
004	Digital Output 3	
005	Digital Output 4	
006	Digital Output 5	
007	Digital Output 6	
008	Digital Output 7	
009	Digital Output 8	
010	Digital Output 9	
011	Digital Output 10	
012	Digital Output 11	
013	Digital Output 12	